

SAILING INSTRUCTIONS
SNIPE CLASS INTERNATIONAL RACING ASSOCIATION

Snipe Canadian and Ontario Championship
Deeds Of gift
The Leckie Trophy
The Oakville Trophy
The Howie Richards Trophy
July 22- 23, 2023
Guelph Community Boating Club
Guelph Ontario

[SP] denotes a rule for which a standard penalty may be applied by the race committee or technical (Changes rule RRS 63.1, A4 and A5).

committee without a hearing or a discretionary penalty applied by the International Jury with a hearing.

[NP] denotes a rule that shall not be grounds for protests by a boat. This changes RRS 60.1(a)

1 RULES

The regatta will be governed by:

- 1.1 The rules as defined in the Racing Rules of Sailing. (RRS)
- 1.2 The SCIRA Rules of Conduct for Conducting National and International Championship Regattas (RoC) available at https://www.snipe.org/images/2021/SCIRA_2021_Rules_of_Conduct_final.pdf.
- 1.4 If there is a conflict between languages the English will take precedence.

2 CHANGES TO SAILING INSTRUCTIONS

- 2.1 Any change to the sailing instructions will be posted before 9:00am on the day it will take effect, except that any change to the schedule of races will be posted by 18:00 on the day before it will take effect.
- 2.2 Any change or amendment to the Sailing Instructions shall be approved with the SCIRA Representative.

3 COMMUNICATIONS WITH COMPETITORS

- 3.1 Notices to competitors will be posted on the official notice board(s) located at <https://sciracanada.com/regatta-registration/>

4. CODE OF CONDUCT

- 4.1 [DP] Competitors and support persons shall comply with reasonable requests from race officials.

5 SIGNALS MADE ASHORE

- 5.1 Signals made ashore will be displayed at the flag pole in front of the club house
- 5.2 When the “AP” race signal is displayed ashore, ‘1 minute’ is replaced with ‘not less than 60 minutes’ in the race signal “AP”. This changes Race Signals.
- 5.3 [DP] Flag D with one sound means ‘Boats shall not leave the [harbour][shore] until this signal is made. The warning signal will not be made before the scheduled time or less than 60 minutes after flag D is displayed.

6 SCHEDULE OF RACES

- 6.1 Dates of racing:

<u>Date</u>	<u>Time of</u> <u>Warning Signal</u>	
July 22, 2023	11:00	Racing
July 23, 2023	10:00	Racing

- 6.2 The Race Committee shall attempt to complete 7-10 races
- 6.3 To alert boats that a race or sequence of races will begin soon, the orange starting line flag will be displayed with one sound at least <insert time> minutes before a warning signal is made.
- 6.4 There will be a competitor meeting at 10:00 July 22, 2023 in front of the club house
- 6.5 No Races will be started after 14:30 on July 23, 2023

7 CLASS FLAGS

- 7.1 The official Class Flag shall be the Snipe Class flag, a Snipe silhouette on a white background.

8 RACING AREAS

8.1 Will be on the water of Guelph Lake.

9 THE COURSES

9.1 The diagrams below show the courses, including the approximate angles between legs, the order in which marks are to be passed. All course marks (except gates) shall be left to port.

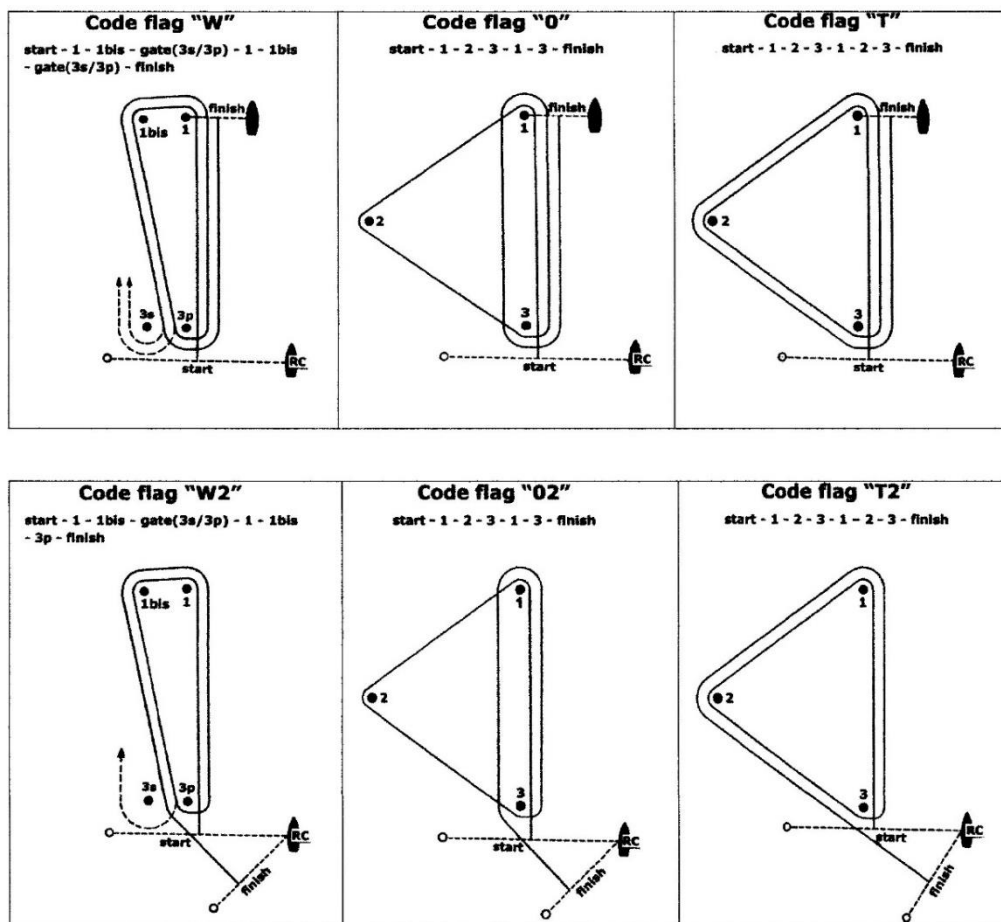

9.2 The course signal (code flag "W", "T", "O", "W2", "T2" or "O2") shall be hoisted with one sound at last one minute before the warning signal. It will remain displayed for not less than five minutes after the start.

9.3 No later than the warning signal, the Race Committee signal boat may display the approximate compass bearing of the first leg.

9.4 If during a race the wind and/or wave action changes to the point where the selected course would be inadvisable (See Course Selection Diagram), the Race Committee shall change the course at any mark. A change of the type of course during the race shall be signalled displaying the new appropriate flag and accompanied by repetitive sounds before the leading boat has passed or rounded the mark.

9.5 The number of legs in a race may be reduced (RRS code flag S) but at least 2 (two) windward legs of the course shall be completed. This changes the RRS 32.2. [*The SCIRA Representative shall be consulted.*]

9.6 The wind speed ranges shall be no less than 5 knots and not exceed 23 knots or in accordance with the Rules of Conduct for Conducting National and International Championships and the applicable Deed of Gift. This changes rule 32.1.

10 MARKS

10.1 Marks 1, 1bis, 2, 3, 3s and 3p will be Orange or White Balls

10.2 New marks, as provided in instruction 13.1, will be Orange or White Balls

10.3 The port-end starting mark will be: An Orange or White Ball

10.4 The finishing marks will be the Port side of the starting line and the committee boat.

10.5 Except at a gate, a Race Committee vessel signalling a change of a leg of the course is a mark as provided in SI 13.2.

10.6 If one of the marks "gate 3s-3p" is not placed, or is not replaced as per RRS 34, the remaining mark shall be left to port. This changes the RRS 34.

10.7 Marks 3, 3s and 3p will be the start finish line.

11 THE START

11.1 The starting line will be between a staff displaying an orange flag on the Race Committee vessel at the starboard end and the course side of the starting mark as provided in instruction 10.3 b.

- 11.2 A boat starting later than 5 minutes after her starting signal will be scored Did Not Start without a hearing. This changes Appendices A4 and A5.
- 11.3 RRS 30.4 is changed so that it will be applied in fleets with more than 45 boats and after the 2nd General Recall for that race.
- 11.4 The Race Committee, after the finish of a race and before the warning signal of a subsequent one, will do its best to post on the Race Committee vessel a list of OCS, or ZPF, UFD or BFD boats. The failure of posting or an incomplete or wrong list will not be grounds for redress. This changes the RRS 62.1(a).

12 CHANGE OF THE NEXT LEG OF THE COURSE

- 12.1 To change the next leg of the course, the Race Committee will lay a new mark (or move the finishing line) and remove the original mark as soon as practicable. When in a subsequent change a new mark is replaced, it will be replaced by an original mark.
- 12.2 Except at a gate, boats shall pass between the race committee boat signalling the change of the next leg and the nearby mark, leaving the mark to port and the Race Committee vessel starboard. This changes the RRS 28.
- 12.3 After the completion of first windward leg of the race the remaining legs may be increased or decreased by not more than 30% of the original length. This changes the RRS 33. [*The SCIRA Representative shall be consulted on any change of course which affects its length.*]
- 12.4 If Mark 1 will be changed in courses “W” or “W2”, Mark 1bis (offset) will no longer be a course mark.

13 THE FINISH

- 13.1 The finish line will be between a staff displaying a Orange flag on a Race Committee vessel and the course side of the finishing mark.
- 13.2 The A flag on the Race Committee boat at the finish means that there will be no more races for the day.

14 TIME LIMITS AND TARGET TIMES

- 14.1 The races will be managed to last 20-60 minutes for the first boat to finish. A different time (shorter or longer) used to complete the race will not be ground for requesting redress. This changes 62.1.
- 14.2 The time limit for the first boat to complete the first lap is 40 minutes from the start. If the first boat fails to complete the first lap within 40 minutes the Race Committee shall abandon the race. For the purpose of this rule a lap means the rounding of Mark 3 (or passing the Gate 3s/3p) for the first time.
- 14.3 The time limit for the first boat to finish the race shall be 1 hour, 30 minutes. Any boat finishing more than 30 minutes after the first boat finishes or failing to finish within 2 hours from the start, whichever is shorter shall be scored Did Not Finish (DNF). This changes RRS 35, A4 and A5.

15 HEARING REQUESTS

- 15.1 Protest forms are available at the race office, located at Club house. Protests and requests for redress or reopening shall be delivered there within the appropriate time limit.
- 15.2 The protest time limit is 90 minutes after the last boat has finished the last race of the day or the Race Committee signals no more racing today, whichever is later.
- 15.3 Notices will be posted no later than 30 minutes after the protest time limit to inform competitors of hearings in which they are parties or named as witnesses. Hearings will be held in the protest room, located at Club house, beginning at the time posted.
- 15.4 Notices of protests by the Race Committee, Technical Committee or Protest Committee will be posted to inform boats under RRS 61.1(b).
- 15.5 The penalty for breaking rules in the SI marked with [SP] may be applied at the discretion of the Race Committee, without a hearing, and shall be the 5% scoring penalty for nearest race completed by the infringing boat but not worse than a DSQ. This changes the RRS 63.1 and the Appendix A5.
- 15.6 Penalties for breaking Class Rules may be less than disqualification. This changes 64.2.
- 15.7 Per Appendix N2.2, SCIRA reserves for itself the right and responsibility to decide issues of eligibility, measurement and equipment. SCIRA may refer any issue to the International Jury for advice.
- 15.8 For the purpose of RRS 64.4(b) the “authority responsible” is the Measurer of the event.
- 15.9 The Jury will abandon the race if, during a redress hearing, they conclude that the Race Committee did not follow Sailing Instructions 9.5, 9.6, 9.7,9.8 and 13.3. This changes the RRS 64.3.
- 15.10 A list of boats that have been penalized for breaking RRS 42, RRS 29.1(OCS) or 30.1(OCS) or 30.2(ZPF) 30.3(UFD), 30.4 (BFD), SI 17.5 and 17.6 will be posted on the Official Notice Board.

16 SCORING

- 16.1 3 races are required to be completed to constitute a series.
- 16.2 (a) When fewer than 6 races have been completed, a boat’s series score will be the total of her race scores.
(b) When from 6 or more races have been completed, a boat’s series score will be the total of her race scores excluding her worst score.

17 [NP][DP] SAFETY REGULATIONS

- 17.1 Before the warning signal of the first race of the day each boat is required to sail past the stern of the Race Committee boat on starboard tack and verbally check in. If no separate check-in boat is on station competitors will check in with the main Race Committee boat. When the Race Committee verbally acknowledges a boat's Sail number, the check-in has been officially noted.
- 17.2 A boat that retires from a race shall notify the Race Committee as soon as possible.

18 REPLACEMENTS OF CREW OR EQUIPMENT

- 18.1 The same crew shall race in all races, except for reasons satisfactory to the Race Committee. Requests for a change of crew shall be submitted in writing to the Chairman. Once a crew has been excused, he/she may not return for the balance of the series.
- 18.2 The same skipper shall sail all races and can be replaced after the first race only, and then only if he/she is obviously incapacitated. If a skipper is replaced the first race shall be the race dropped or scored DNC.
- 18.3 [DP] Substitution of hull, sails, appendages, and rig will not be allowed unless authorized in writing by the Andrew Rowlinson. Requests for substitution shall be made to the committee at the first reasonable opportunity, which may be after the race.

19 [DP] RADIO COMMUNICATIONS

- 19.0 A boat that is racing shall not make voice or data transmissions and shall not receive voice or data communication that is not available to all boats, except in an emergency or when using equipment provided by the race committee.

Signatures: Andrew Rowlinson - Race Committee Chairman Ryan Perry - SCIRA Representative