

2021 Canadian Senior and Junior Championships & Ontario Open Championship



Deeds of Gift:

The Leckie Trophy
The Oakville Trophy
The Howie Richards Trophy

September 18-19, 2021
Guelph Community Boating Club, Guelph, Ontario
Organizing Authority (OA) – Snipe Class International Racing Association – Canada

1. RULES

- 1.1. Races shall be conducted in accordance with the following rules:
- 1.2. The rules as defined in *The Racing Rules of Sailing* (RRS).
- 1.3. The SCIRA Rules of Conduct for Conducting National and International Championship Regattas (RoC) and the trophy restrictions of The Leckie Trophy, The Oakville Trophy and The Howie Richards Trophy will apply. Any conflict arising between the Deed of Gift and the SCIRA Rules of Conduct shall be resolved by the application of the Rules of Conduct.
- 1.4. In case of conflict between the Notice of Race and the Sailing Instructions, the Sailing Instructions shall prevail.
- 1.5. If there is a conflict between languages the English text will take precedence.
- 1.6. Appendix T – Arbitration – may apply; and the Arbitrator at an Arbitration Meeting may be a member of the Protest Committee if the arbitration continues to a Protest Hearing.

2. NOTICES TO COMPETITORS

- 2.1 Notices to competitors will be posted on the official notice board(s) located on the outside of the GCBC clubhouse.

3. CHANGES TO SAILING INSTRUCTIONS

- 3.1. Any change to the sailing instructions will be posted before **0900** on the day it will take effect, except that any change to the schedule of races will be posted by **1800** on the day before it will take effect.

3.2. Any change or amendment to the Sailing Instructions shall be approved with the SCIRA Representative.

4 SIGNALS MADE ASHORE

4.1 Signals made ashore will be displayed on the flagpole located in front of the GCBC clubhouse.

4.2 When flag AP is displayed ashore, '1 minute' is replaced with 'not less than 60 minutes' in the race signal AP.

4.3 When flag Y is displayed ashore, rule 40 applies at all times while afloat. This changes the Part 4 preamble.

5 SCHEDULE OF RACES

5.1 Dates of racing:

<u>Date</u>	<u>Time of first Warning Signal</u>	
Saturday, September 17	11:00	Racing
Sunday, September 18	10:30	Racing

5.2 The Race Committee shall attempt to complete **seven (7-10)** races.

5.3 No more than **four (7)** races shall be sailed per day.

5.4 To alert boats that a race or sequence of races will begin soon, an orange flag will be displayed with one sound at least four minutes before a warning signal is displayed.

5.5 On the last day of scheduled racing, no warning signal will be made after **1430**.

5.5 There shall be a competitor's meeting prior to racing on Saturday, September 18 at 10:00 in front of the GCBC building.

6. CLASS FLAGS

6.1 The official Class Flag shall be the Snipe Class flag, a red Snipe on a white background.

7. RACING AREAS

7.1 Racing will take place on the waters of Guelph Lake.

THE COURSES

8.1. The diagrams below show the courses, including the approximate angles between legs, the order in which marks are to be passed.

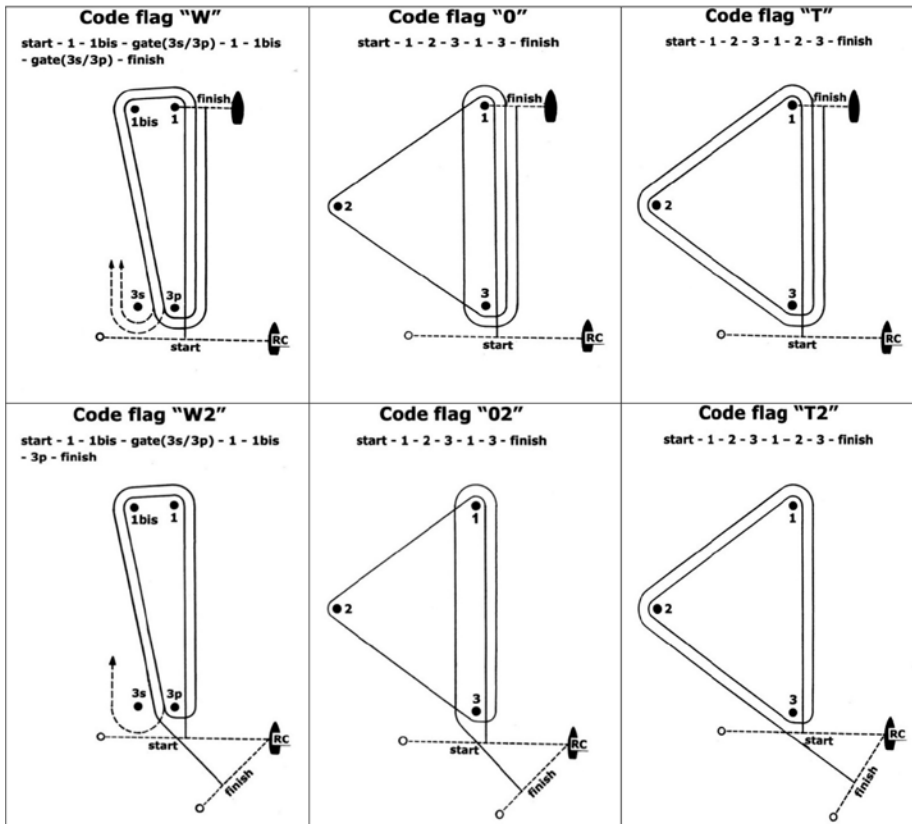

- 8.2. The course "W", "T", "O", "W2", "T2" or "O2" shall be displayed on the RC boat at least one minute before the warning signal. It shall remain displayed for ten minutes after the start.
- 8.3. No later than the warning signal, the race committee signal boat will display the approximate compass bearing of the first leg
- 8.4. The number of legs in a race may be reduced (using the shorten course procedure, RRS code flag S) only after at least 2 (two) windward legs of the race are completed. This changes RRS 32.2.
- 8.5. If during a race the wind and/or wave action changes to the point where the selected course would be inadvisable (See Course Selection Diagram), the Race Committee may change the course at any mark. A change of the type of course during the race shall be signalled displaying the new appropriate flag and accompanied by repetitive sounds before the leading boat has passed or rounded the mark.

9. MARKS

- 9.1. Marks 1, 1bis, 2, 3s and 3p will be orange or white balls.
- 9.2. New marks used in accordance with instruction 12.1 shall be orange or white balls.
- 9.3. The starting mark and finishing mark shall be an orange ball or a racing mark as per diagram 8.1
- 9.4. A race committee vessel signaling a change of leg of the course is a mark as provided in instruction 12.1

10. THE START

- 10.1 Races shall be started in accordance with RRS 26.
- 10.2 The starting line will be between an orange flag on the Race Committee boat at the starboard end and the course side of the port end starting mark.
- 10.3 A boat starting later than 5 minutes after her starting signal will be scored Did Not Start without a hearing. This changes rules A4 and A5.
- 10.4 RRS 30.4 ('Black Flag Rule') shall not be used.
- 10.5 The Race Committee, after the finish of a race and before the warning signal of a subsequent one, will do it's best to post on the Race Committee boat a list of OCS and/or ZPF boats. The failure of posting or an incomplete or wrong list will not be grounds for redress. This changes RRS 62.1(a).

11. RECALLS

- 11.1 Individual recalls shall be signaled in accordance with RRS 29. An attempt to hail the On Course Side competitors shall be made, but failure to be hailed, the timing of such a hail, or failure to hear a hail is insufficient cause for redress under RRS 62.1(a). This changes RRS 60.1(a).

12. CHANGE OF THE NEXT LEG OF THE COURSE

- 12.1 To change the next leg of the course, the race committee will lay a new mark (or move the finishing line) and remove the original mark as soon as practicable.
- 12.2 Except at a gate, boats shall pass between the race committee boat signalling the change of the next leg and the nearby mark, leaving the mark to port and the race committee boat to starboard. This changes RRS 28.1.
- 12.3 After the completion of the first windward leg of the race the remaining legs may be increased or decreased (RRS 33 +/-) by not more than 50% of original length. This changes RRS 33).

Commented [DS1]: WS usually says 50%

13. THE FINISH

- 13.1. The finish line will be between an orange flag on a Race Committee boat and the course side of the finishing mark The finishing marks will be as indicated in Diagram 8.1 (Either an orange ball or inflatable)

14. PENALTY SYSTEM

- 14.1A boat that has taken a penalty under RRS 44.1 shall complete an acknowledgment form at the protest desk within the protest time limit.

15. TIME LIMITS AND TARGET TIMES

- 15.1. The races will be managed to last 60-75 minutes for the first boat to finish. A different time (shorter or longer) used to complete the race will not be ground for requesting redress.
- 15.2. The time limit for the first boat to complete the first lap is 40 minutes from the start. If the first boat fails to complete the first lap within 40 minutes, the Race Committee shall abandon the race. For the purpose of this Rule a lap means the rounding of Mark 3 (or passing Gate 3s/3p) for the first time.
- 15.3. The time limit for the first boat to finish shall be 90 minutes. Any boat finishing more than 30 minutes after the first boat sails the course and finishes or failing to finish within 2 hours from the start, whichever is shorter, shall be scored Did Not Finish (DNF). This changes RRS 35, A4 and A5.

16. PROTESTS AND REQUESTS FOR REDRESS

- 16.1. Protest forms are available at the race office, located at the EYC Dry Sail building. Protests and requests for redress or reopening shall be delivered there within the appropriate time limit.
- 16.2. The protest time limit is 60 minutes after the posted race committee dock time.
- 16.3. Notices will be posted no later than 30 minutes after the protest time limit to inform competitors of hearings in which they are parties or named as witnesses. Hearings will be held in the protest room, located at the Outer Harbour Centreboard Club, beginning at the time posted.
- 16.4. Notices of protests by the race committee or protest committee will be posted to inform boats under rule 61.1(b).
- 16.5. Within the protest time limit, a list of boats that have been penalized for breaking rule 42 or rule 29 and 30 will be posted. The time limit for a boat so notified to file a request for redress is 30 minutes after that posting. This changes rule 62.2.
- 16.6. Any boat intending to file a request for redress, alleging that an action or omission on the part of Race Committee has made her finishing position or series score significantly worse, shall notify the Race Committee immediately after finishing that race. This modifies RRS 62.2. This instruction does not apply to request for redress resulting from scoring penalties applied without a hearing by the Jury or Race Committee or to request for redress with respect to alleged scoring errors.
- 16.7. Breaches of instructions 18, 19.3, 20.1, 21, 23, and 24 will not be grounds for a protest by a boat. This changes rule 60.1(a).
- 16.8. Penalties for breaking instruction 23 may be less than disqualification or will result in denial of access of the coach boat, if the protest committee so decides.
- 16.9. The penalty for breaking instructions 18 and 21 shall be the 5% scoring penalty for the first race competed in by the infringing boat on the day of infraction but not worse than the number of points corresponding to DSQ.
- 16.10. Penalties for breaking Class Rules, or SI 20.1, may be less than disqualification. The scoring abbreviation for a discretionary penalty imposed under this instruction will be DPI.
- 16.11. On the last scheduled day of racing a request for reopening a hearing shall be delivered:

- a. within the protest time limit if the requesting party was informed of the decision on the previous day;
 - b. no later than 30 minutes after the requesting party was informed of the decision on that day. This changes rule 66.
- 16.12 On the last scheduled day of racing a request for redress based on a protest committee decision shall be delivered no later than 30 minutes after the decision was posted. This changes rule 62.2.
- 16.13 The use of team racing tactics shall not be tolerated. If the Race Committee (acting under RRS 32.1(e)) or Protest Committee determines that the use of team racing tactics may have significantly influenced the outcome of a race they shall order that race abandoned and, if possible, re-sailed excluding the participation of the infringing boat(s). This modifies RRS 36. If the race is not re-sailed the infringing boat(s) shall be subject to protest and disqualification.
- 16.14 For the purpose of rule 64.3(b) RRS the "authority responsible" is the Measurer of the event.
- 16.15 The Jury shall abandon the race if, during a redress hearing, they conclude that the Race Committee did not follow sailing instructions 9.4 and 12.3. This changes rule 64.2 This changes rule 64.2.

17. SCORING

- 17.1. Three (3) races are required to be completed to constitute a series.
- 17.2. When fewer than six (6) races have been completed, a boat's series score shall be the total of her race scores.
- 17.3. When six or more races have been completed, a boat's series score shall be the total of her race scores, excluding her worst score.

18. SAFETY REGULATIONS

- 18.1 Before the warning signal of the first race of the day each boat is required to sail past the stern of the race committee boat on starboard tack and verbally check in. The check-in boat will display a code flag "L" while on station prior to the first warning signal.
- 18.1. When the Race Committee verbally acknowledges a boat's sail number, the check-in has been officially noted.
- 18.2. A boat that retires from a race shall notify the race committee as soon as possible.

19. REPLACEMENT OF CREW OR EQUIPMENT

- 19.1. The same crew shall race in all races, except for reasons satisfactory to the Race Committee. Requests for a change of crew shall be submitted in writing to the Chairman. Once a crew has been excused, he/she may not return for the balance of the series.
- 19.2. The same skipper shall sail all races and can be replaced after the first race only, and then only if he/she is obviously incapacitated. If a skipper is replaced the first race shall be dropped or scored DNC.
- 19.3. Substitution of damaged or lost equipment will not be allowed unless authorized by the Race Committee. Requests for substitution shall be made to the race committee at the first reasonable opportunity.

20. EQUIPMENT AND MEASUREMENT CHECKS

20.1 A boat or equipment may be inspected at any time for compliance with the class rules and sailing instructions. On the water, a boat can be instructed by a member of the Race Committee or technical committee to proceed immediately to a designated area for inspection.

21. EVENT ADVERTISING

21.1 Boats shall display event advertising if supplied by the organizing authority.

22. RIGHTS TO USE NAME AND LIKENESS

22.1 By participating in this event, competitors automatically grant to the SCIRA, the organizing authority, and the event sponsors the right, in perpetuity, to make, use, and show, at their discretion, any photography, audio and video recording, and other reproductions of them made at the venue or on the water from the time of their arrival at the venue, until their final departure, without compensation.

23. SUPPORT BOATS

23.1. At the warning signal, coaches must be positioned at least 50 meters below the starting line. After the starting signal coaches may follow the fleet, but only on the port side of the course and must stay 50 meters from any mark.

23.2. Coaches may not communicate with competitors after the warning signal for any race until after the competitors have finished of the race.

23.3. Coaches shall register with the Regatta Office and obtain a designated identifier that must be displayed.

24. TRASH DISPOSAL

24.1. Trash may be placed aboard support or official boats.

25. PRIZES

Prizes, at a minimum, will be awarded to the following:

25.1. The Leckie Trophy will be awarded to the top Canadian Crew

25.2. The Oakville Trophy will be awarded to the winning crew regardless of division or nationality

25.3. The Howie Richards Trophy will be awarded to the top junior crew

25. DISCLAIMER OF LIABILITY

Competitors participate in the regatta entirely at their own risk. See rule 4, Decision to Race. The organizing authority will not accept any liability for material damage or personal injury or death sustained in conjunction with or prior to, during, or after the regatta.

26. INSURANCE

27.1 Each participating boat shall be insured with valid third-party liability insurance with a minimum cover of \$300,000 US per incident or the equivalent.

Signatures:

Irene McNeill

Andrew Rowlinson – Race Officers

Julian Inglis - SCIRA National Secretary
